

F D W TYPE

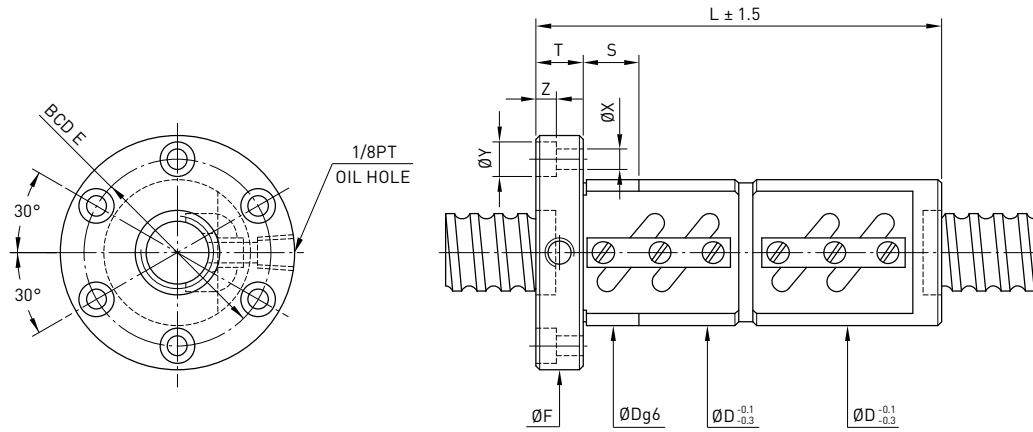

Model	Size		Ball Dia.	PCD	RD	Circuits	Stiffness kgf / μm K	Dynamic Load 1×10^6 revs C (kgf)	Static Load Co (kgf)	Nut		Flange			Bolt			Fit
	Nominal Dia.	Lead								D	L	F	T	BCD-E	X	Y	Z	S
16-5B2	16	5	3.175	16.6	13.324	2.5x2	65	1385	2799	40	110	64	12	51	5.5	9.5	5.5	24
16-5B1				16.6	13.324	2.5x1	32	763	1400	40	80	64	12	51	5.5	9.5	5.5	24
16-5C1				16.6	13.324	3.5x1	46	1013	1946	40	90	64	12	51	5.5	9.5	5.5	24
20-5B1	20	6	3.969	20.6	17.324	2.5x1	38	837	1733	44	80	68	12	55	5.5	9.5	5.5	24
20-5B2				20.6	17.324	2.5x2	76	1519	3465	44	110	68	12	55	5.5	9.5	5.5	24
20-6B1				20.8	16.744	2.5x1	40	1139	2187	48	92	72	12	59	5.5	9.5	5.5	24
20-6C1	25	5	3.175	20.8	16.744	3.5x1	55	1512	3041	48	104	72	12	59	5.5	9.5	5.5	24
25-5A2				25.6	22.324	1.5x2	54	1092	2622	50	102	73	11	61	5.5	9.5	5.5	24
25-5B1				25.6	22.324	2.5x1	46	939	2209	50	80	74	12	62	5.5	9.5	5.5	24
25-5B2	25	6	3.969	25.6	22.324	2.5x2	90	1704	4417	50	110	74	12	62	5.5	9.5	5.5	24
25-5C1				25.6	22.324	3.5x1	68	1252	3085	50	90	74	12	62	5.5	9.5	5.5	24
25-6B2				25.8	21.744	2.5x2	94	2304	5524	56	128	82	12	69	6.6	11	6.5	24
25-6C1	28	5	3.175	25.8	21.744	3.5x1	66	1690	3844	56	104	82	12	69	6.6	11	6.5	24
25-10B1				26	21.132	2.5x1	48	1592	3237	60	122	86	16	73	6.6	11	6.5	24
28-5B1				28.6	25.324	2.5x1	51	984	2466	55	80	85	12	69	6.6	11	6.5	24
28-5B2	28	6	3.969	28.6	25.324	2.5x2	98	1785	4932	55	110	85	12	69	6.6	11	6.5	24
28-6A2				28.6	25.324	1.5x2	59	1150	2960	55	110	85	12	69	6.6	11	6.5	24
28-6B2				28.6	25.324	2.5x2	98	1776	4980	55	123	85	12	69	6.6	11	6.5	24
32-4B2	32	4	2.381	32.25	29.792	2.5x2	91	1071	3582	54	93	81	12	67	6.6	11	6.5	24
32-5B1				32.6	29.324	2.5x1	55	1039	2833	58	80	84	12	71	6.6	11	6.5	24
32-5B2				32.6	29.324	2.5x2	109	1886	5666	58	110	84	12	71	6.6	11	6.5	24
32-5C1	32	5	3.175	32.6	29.324	3.5x1	76	1388	3967	58	90	84	12	71	6.6	11	6.5	24
32-6B1				32.8	28.744	2.5x1	57	1409	3510	62	92	88	12	75	6.6	11	6.5	24
32-6B2				32.8	28.744	2.5x2	112	2556	7020	62	128	88	12	75	6.6	11	6.5	24
32-6C1	32	6	3.969	32.8	28.744	3.5x1	78	1888	4936	62	104	88	12	75	6.6	11	6.5	24
32-8A2				33	28.132	1.5x2	70	2082	5151	66	135	100	15	82	9	14	8.5	30
32-8B1				33	28.132	2.5x1	58	1810	4227	66	110	100	16	82	9	14	8.5	30
32-8B2	32	8	4.763	33	28.132	2.5x2	115	3284	8453	66	158	100	16	82	9	14	8.5	30
32-8B3				33	28.132	2.5x3	168	4653	12678	74	205	108	16	90	9	14	8.5	30
32-8C1				33	28.132	3.5x1	82	2428	5948	66	126	100	16	82	9	14	8.5	30
32-10A2	32	10	6.350	33.4	26.91	1.5x2	72	3051	6612	74	167	108	15	90	9	14	8.5	30
32-10B1				33.4	26.91	2.5x1	58	2651	5600	74	122	108	16	90	9	14	8.5	30
32-10B2				33.4	26.91	2.5x2	118	4810	11199	74	182	108	16	90	9	14	8.5	30
32-10C1	32	12	6.350	33.4	26.91	3.5x1	86	3519	7785	74	142	108	16	90	9	14	8.5	30
32-12B1				33.4	26.91	2.5x1	62	2602	5510	74	153	108	18	90	9	14	8.5	30
32-12B2				33.4	26.91	2.5x2	118	4810	11199	74	232	108	16	90	9	14	8.5	30
32-12C1	32	12	6.350	33.4	26.91	3.5x1	84	3518	7784	74	166	108	16	90	9	14	8.5	30

Remark : Stiffness values listed above are derived from theoretical formula while preload is 10% of dynamic load rating.

F D W TYPE

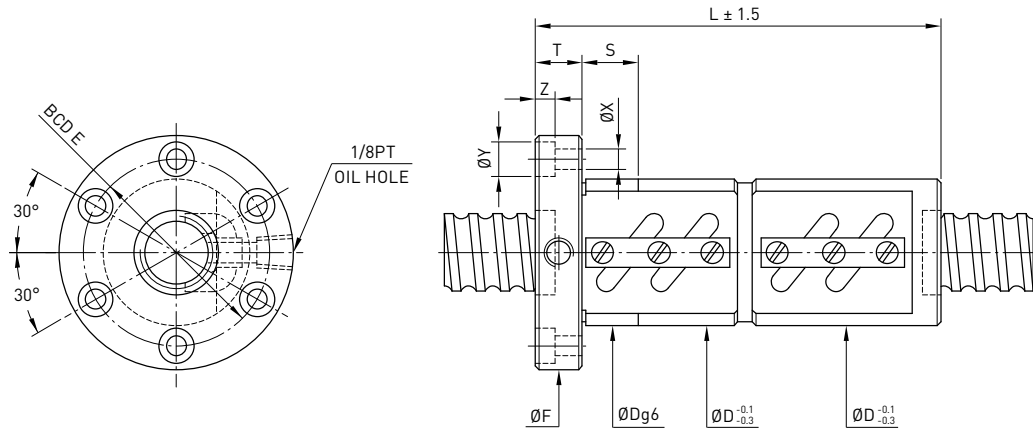

Model	Size		Ball Dia.	PCD	RD	Circuits	Stiffness kgf / μm K	Dynamic Load 1×10^6 revs C (kgf)	Static Load Co (kgf)	Nut		Flange			Bolt			Fit
	Nominal Dia.	Lead								D	L	F	T	BCD-E	X	Y	Z	
36-6B1	36	6	3.969	36.8	32.744	2.5x1	62	1486	3969	65	92	100	12	82	6.6	11	6.5	24
36-6B2				36.8	32.744	2.5x2	121	2696	7937	65	128	100	12	82	6.6	11	6.5	24
36-12A2		12	4.763	37	32.132	1.5x2	80	2557	6693	70	155	108	15	90	9	14	8.5	30
36-12B1				37.4	30.91	2.5x1	67	2812	6334	75	126	120	16	98	11	17.5	11	30
36-10B2		10	6.350	37.4	30.91	2.5x2	132	5105	12669	75	184	120	18	98	11	17.5	11	30
36-12B2				37.4	30.91	2.5x2	130	5105	12668	75	206	120	18	98	11	17.5	11	30
36-8A2		8	4.763	37	32.132	1.5x2	77	2217	5669	70	135	108	15	90	9	14	8.5	30
36-8B2				37	32.132	2.5x2	126	3489	9606	70	158	108	15	90	9	14	8.5	30
40-5B1	40	5	3.175	40.6	37.324	2.5x1	65	1141	3567	68	84	102	16	84	9	14	8.5	30
40-5B2				40.6	37.324	2.5x2	132	2071	7134	68	114	102	16	84	9	14	8.5	30
40-6B2		6	3.969	40.8	36.744	2.5x2	136	2817	8855	70	132	104	16	86	9	14	8.5	30
40-8B1				8	4.763	41	36.132	2.5x1	69	2003	5302	74	110	108	16	90	9	14
40-8B2		41	36.132			2.5x2	137	3634	10603	74	158	108	16	90	9	14	8.5	30
40-8B3		41	36.132	2.5x3	200	5150	15904	74	210	108	15	90	9	14	8.5	30		
40-8C1		41	36.132	3.5x1	96	2679	7438	74	126	108	16	90	9	14	8.5	30		
40-10A2		10	6.350	41.4	34.91	1.5x2	87	3418	8398	82	170	124	18	102	11	17.5	11	30
40-10B1	41.4			34.91	2.5x1	72	2959	7069	84	132	125	18	104	11	17.5	11	30	
40-10B2	12	7.144	41.4	34.91	2.5x2	145	5370	14138	84	192	125	18	104	11	17.5	11	30	
40-10C1			41.4	34.91	3.5x1	102	3932	9841	84	152	125	18	104	11	17.5	11	30	
40-12A2	12	7.144	41.6	34.299	1.5x2	88	4006	9404	86	160	128	18	106	11	17.5	11	30	
40-12B1			41.6	34.299	2.5x1	70	3425	7837	86	153	128	18	106	11	17.5	11	40	
40-12B2	41.6	34.299	2.5x2	141	6217	15674	86	225	128	18	106	11	17.5	11	40			
40-12C1	41.6	34.299	3.5x1	103	4637	11146	86	179	128	18	106	11	17.5	11	30			
40-16A2	16	7.144	41.6	34.299	1.5x2	83	4007	9405	86	214	128	18	106	11	17.5	11	40	
40-16B1			41.6	34.299	2.5x1	72	3425	7837	86	182	128	18	106	11	17.5	11	40	
40-16B2	41.6	34.299	2.5x2	143	6216	15674	86	272	128	22	106	11	17.5	11	30			
45-10B1	45	10	6.350	46.4	39.91	2.5x1	76	3111	7953	88	134	132	18	110	11	17.5	11	30
45-10B2				46.4	39.91	2.5x2	156	5655	15905	88	194	132	18	110	11	17.5	11	30
45-12B2		12	7.938	46.8	38.688	2.5x2	162	7627	19799	96	230	142	22	117	13	20	13	40
45-16B2	16	7.144	46.6	39.299	2.5x2	158	6636	17895	90	278	132	18	110	11	17.5	11	30	
50-5A2	50	5	3.175	50.6	47.324	1.5x2	96	1447	5382	80	107	114	16	96	9	14	8.5	30
50-5A3				50.6	47.324	1.5x3	143	2051	8072	80	127	114	16	96	9	14	8.5	30
50-6B2		6	3.969	50.8	46.744	2.5x2	161	3093	11149	84	134	118	16	100	9	14	8.5	30
50-6B3				50.8	46.744	2.5x3	235	4384	16723	84	170	118	16	100	9	14	8.5	30
50-8B1		8	4.763	51	46.132	2.5x1	81	2206	6705	87	112	128	18	107	11	17.5	11	30
50-8B2				51	46.132	2.5x2	165	4004	13409	87	160	128	18	107	11	17.5	11	30
50-8B3		51	46.132	2.5x3	244	5674	20114	87	208	128	18	107	11	17.5	11	30		
50-10B1		10	6.350	51.4	44.91	2.5x1	88	3245	8918	93	133	135	18	113	11	17.5	11	30

Remark : Stiffness values listed above are derived from theoretical formula while preload is 10% of dynamic load rating.

F D W TYPE

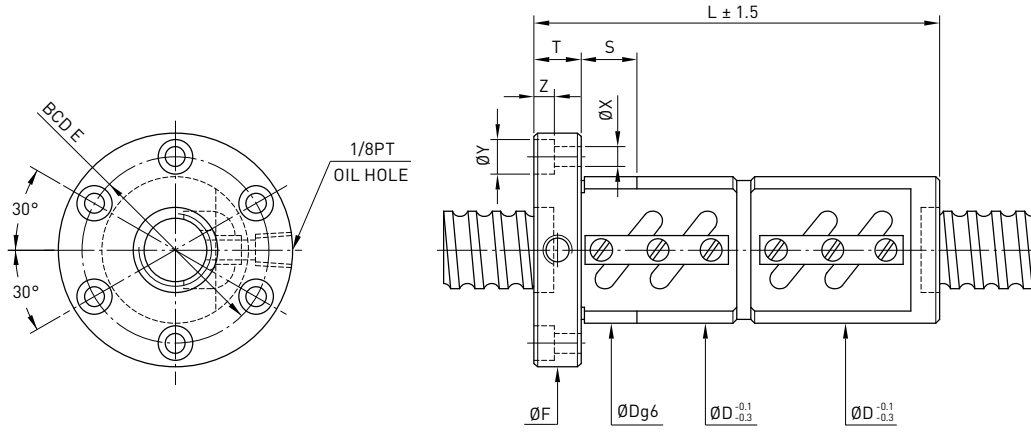

Model	Size		Ball Dia.	PCD	RD	Circuits	Stiffness kgf / μm K	Dynamic Load 1×10^6 revs C (kgf)	Static Load Co (kgf)	Nut		Flange			Bolt			Fit	
	Nominal Dia.	Lead								D	L	F	T	BCD-E	X	Y	Z		S
50-10B2	50	10	6.350	51.4	44.91	2.5x2	173	5923	17670	94	194	135	18	114	11	17.5	11	30	
50-10B3				51.4	44.91	2.5x3	255	8394	26505	94	254	135	18	114	11	17.5	11	30	
50-10C1		12	7.938	51.4	44.91	3.5x1	120	4393	12481	94	154	135	18	114	11	17.5	11	30	
50-12B1				51.8	43.688	2.5x1	90	4367	10918	100	159	146	22	122	14	20	13	40	
50-12B2		16	9.525	7.938	51.8	43.688	2.5x2	178	8022	22094	102	232	150	22	125	13	20	13	40
50-12C1					51.8	43.688	3.5x1	123	5875	15380	102	184	150	22	125	13	20	13	40
50-16B2		20	9.525	7.938	51.8	43.688	2.5x2	174	7918	21837	100	280	146	22	122	14	20	13	40
50-20B1					51.8	43.688	2.5x1	90	4367	10918	100	227	146	28	122	14	20	13	40
55-10C1		55	10	6.350	56.4	49.91	3.5x1	132	4562	13661	100	154	140	18	118	11	17.5	11	40
55-12B2			12	7.938	56.8	48.688	2.5x2	185	8392	24390	105	232	154	22	127	13	20	13	40
63-8A2	63	8	4.763	64	59.132	1.5x2	107	2826	10129	104	142	146	18	124	11	17.5	11	40	
63-8A3				64	59.132	1.5x3	154	4004	15193	104	174	146	18	124	11	17.5	11	40	
63-10B2		10	6.350	64.4	57.91	2.5x2	206	6533	22371	110	196	152	20	130	11	17.5	11	30	
63-10B3				64.4	57.91	2.5x3	305	9258	33556	110	256	152	20	130	11	17.5	11	30	
63-12B2		12	7.938	6.350	64.8	56.688	2.5x2	214	8943	28062	118	232	166	22	141	13	20	13	40
63-16B2					65.2	55.466	2.5x2	280	14862	46009	124	296	172	22	147	13	20	13	40
63-20B2		20	9.525	6.350	65.2	55.466	2.5x2	280	14862	46009	124	334	172	22	147	13	20	13	40
70-10B2		70	10	6.350	71.4	64.91	2.5x2	228	6843	25011	124	196	170	20	145	13	20	13	40
70-10B3					71.4	64.91	2.5x3	334	9698	37516	124	256	170	20	145	13	20	13	40
70-12B2			12	7.938	71.8	63.688	2.5x2	236	9382	31275	130	232	178	22	152	13	20	13	40
70-12B3	71.8				63.688	2.5x3	336	13296	46912	130	302	178	22	152	13	20	13	40	
70-20B2	20		9.525	7.938	72.2	62.466	2.5x2	300	15644	51502	130	325	186	28	158	18	26	17.5	60
80-10B2					81.4	74.91	2.5x2	251	7202	28538	130	200	178	22	152	13	20	13	40
80-10B3	80	10	6.350	81.4	74.91	2.5x3	368	10207	42807	130	260	178	22	152	13	20	13	40	
80-12B2				12	7.938	81.8	73.688	2.5x2	257	9797	35422	136	232	185	22	159	13	20	13
80-12B3		81.8	73.688			2.5x3	380	13884	53132	136	302	185	22	159	13	20	13	40	
80-16B2		16	9.525	7.938	82.2	72.466	2.5x2	340	16485	58851	145	302	210	28	174	18	26	17.5	50
80-16B3					82.2	72.466	2.5x3	498	23363	88276	145	398	210	28	174	18	26	17.5	50
80-20B2		20	9.525	7.938	82.2	72.466	2.5x2	338	16485	58851	145	345	210	28	174	18	26	17.5	50
80-20B3					82.2	72.466	2.5x3	498	23363	88276	145	470	210	28	174	18	26	17.5	50
100-12B2		100	12	7.938	101.8	93.688	2.5x2	301	10761	44596	160	240	224	28	188	18	26	17.5	50
100-12B3					101.8	93.688	2.5x3	452	15251	66894	160	312	224	28	188	18	26	17.5	50
100-16B2			16	9.525	7.938	102.2	92.466	2.5x2	400	18123	74425	170	308	248	32	205	22	32	21.5
100-16B3	102.2					92.466	2.5x3	595	25684	111637	170	404	248	32	205	22	32	21.5	60
100-20B2	20		9.525	7.938	102.2	92.466	2.5x2	400	18123	74425	170	350	248	32	205	22	32	21.5	60
100-20B3					102.2	92.466	2.5x3	595	25684	111637	170	475	248	32	205	22	32	21.5	60

Remark : Stiffness values listed above are derived from theoretical formula while preload is 10% of dynamic load rating.